



**CHICAGO**  
**Electric Power Tools**

# **10 INCH COMPOUND SLIDE MITER SAW**

**Model 45885**

## **ASSEMBLY AND OPERATING INSTRUCTIONS**



3491 Mission Oaks Blvd., Camarillo, CA 93011  
Visit our Web site at <http://www.harborfreight.com>

Copyright © 2001 by Harbor Freight Tools®. All rights reserved. No portion of this manual or any artwork contained herein may be reproduced in any shape or form without the express written consent of Harbor Freight Tools.

**For technical questions and replacement parts, please call 1-800-444-3353**

**REV 05/03**



## Specifications

ITEM	DESCRIPTION
Power Consumption	110 VAC , 60 Hz , 1650 W atts , 2.2 H P No load: 5A ; Startup: 15A
Power Cord	6-1/2 feet, UL approved , 14 AW G , 3 prong plug ; double insulated
Motor Speed	5000 RPM
Fence Dimensions	22-3/4 x 4-7/8 inches
Table Dimensions	19-3/4 ( W ) x 6-1/4 ( H ) inches
Table Positive Stops	0 , 15 , 22.5 , 30 , 45 ( left and right ) degree m iter
Cutting Capacity	3-1/2 ( D ) x 12 ( L ) inches at 90 deg . ( front to back ) 1-3/4 ( D ) x 10 ( L ) inches at 45 deg . ( front to back )
Maximum Blade Height	4-1/2 inches
Saw Blade Tilt Capacity	0 to 45 degrees ( right and left ) m iter 0 to 45 ( L ) degrees compound
Shaft Diameter	5/8 inch arbor
Scales	Inches and degrees
Saw Blade	10 inch , carbide tipped ; 0.065 inches ( W )
Features	Push-down lock Retractable blade guard Single slide bar extension
Accessories	Dust collector bag 2 carbon replacement brushes for motor
Net Weight	48 lbs

## Save This Manual

You will need the manual for the safety warnings and precautions, assembly instructions, operating and maintenance procedures, parts list and diagram. Keep your invoice with this manual. Write the invoice number on the inside of the front cover. Keep the manual and invoice in a safe and dry place for future reference.

## Safety Warnings and Precautions

**WARNING:** When using tool, basic safety precautions should always be followed to reduce the risk of personal injury and damage to equipment.





**Read all instructions before using this tool!**

1. **Keep work area clean.** Cluttered areas invite injuries.
2. **Observe work area conditions.** Do not use machines or power tools in damp or wet locations. Don't expose to rain. Keep work area well lighted. Do not use electrically powered tools in the presence of flammable gases or liquids.



3. **Keep children away.** Children must never be allowed in the work area. Do not let them handle machines, tools, or extension cords.
4. **Store idle equipment.** When not in use, tools must be stored in a dry location to inhibit rust. Always lock up tools and keep out of reach of children.
5. **Do not force tool.** It will do the job better and more safely at the rate for which it was intended. Do not use inappropriate attachments in an attempt to exceed the tool capacity.
6. **Use the right tool for the job.** Do not attempt to force a small tool or attachment to do the work of a larger industrial tool. There are certain applications for which this tool was designed. Do not modify this tool and do not use this tool for a purpose for which it was not intended.
7. **Dress properly.** Do not wear loose clothing or jewelry as they can be caught in moving parts. Protective, electrically non-conductive clothes and non-skid footwear are recommended when working. Wear restrictive hair covering to contain long hair.
8. **Use eye and ear protection.** Always wear ANSI approved impact safety goggles. Wear a full face shield if you are producing metal filings or wood chips. Wear an ANSI approved dust mask or respirator when working around metal, wood, and chemical dusts and mists.
9. **Do not overreach.** Keep proper footing and balance at all times. Do not reach over or across running machines.
10. **Maintain tools with care.** Keep tools sharp and clean for better and safer performance. Follow instructions for lubricating and changing accessories. Inspect tool cords periodically and, if damaged, have them repaired by an authorized technician. The handles must be kept clean, dry, and free from oil and grease at all times.
11. **Disconnect power.** Unplug tool when not in use.
12. **Remove adjusting keys and wrenches.** Check that keys and adjusting wrenches are removed from the tool or machine work surface before plugging it in.
13. **Avoid unintentional starting.** Be sure the switch is in the Off position when not in use and before plugging in. Do not carry any tool with your finger on the trigger, whether it is plugged in or not.
14. **Stay alert.** Watch what you are doing, use common sense. Do not operate any tool when you are tired.
15. **Take caution as some woods contain preservatives such as copper chromium arsenate (CCA) which can be toxic.** When cutting these materials extra care should be taken to avoid inhalation and minimize skin contact.
16. **Check for damaged parts.** Before using any tool, any part that appears damaged should be carefully checked to determine that it will operate properly and perform its intended function. Check for alignment and binding of moving parts; any broken parts or mounting fixtures; and any other condition that may affect proper operation. Any part that is damaged should be properly repaired or replaced by a qualified technician. Do not use the tool if any switch does not turn On and Off properly.



- 
- 
- 
- 
17. **Guard against electric shock.** Prevent body contact with grounded surfaces such as pipes, radiators, ranges, and refrigerator enclosures.
  18. **Replacement parts and accessories.** When servicing, use only identical replacement parts. Use of any other parts will void the warranty. Only use accessories intended for use with this tool. Approved accessories are available from Harbor Freight Tools.
  19. **Do not operate tool if under the influence of alcohol or drugs.** Read warning labels on prescriptions to determine if your judgment or reflexes are impaired while taking drugs. If there is any doubt, do not operate the tool.
  20. **Use proper size and type extension cord.** If an extension cord is required, it must be of the proper size and type to supply the correct current to the tool without heating up. Otherwise, the extension cord could melt and catch fire, or cause electrical damage to the tool. This tool requires use of an extension cord of **0 to 15 amps** capability (up to 50 feet), with wire size rated at **14 AWG**. Longer extension cords require larger size wire. If you are using the tool outdoors, use an extension cord rated for outdoor use. (signified by “WA” on the jacket).
  21. **Maintenance.** For your safety, service and maintenance should be performed regularly by a qualified technician.
  22. **Do not disable blade guard.** Do not saw without proper blade guard in place.
  23. **Examine blade before using.** Before each use, examine blade for chips, cracks, or other damage. Do not use if damaged.
  24. **Do not use without first mounting saw to a workbench.**
  25. **Check for tightness on all saw adjustments before using.**
  26. **Keep hands away from moving saw blade.** If the workpiece to be cut is less than 4 inches long, do not hold with your hand, use a clamp. Do not remove jammed or cutoff pieces until the saw blade has stopped and the Line Cord is unplugged.
  27. **Cut only the proper type of material.** Never cut ferrous metals or masonry.

**Note:** Performance of this tool may vary depending on variations in local line voltage. Extension cord usage may also affect tool performance.

**Warning:** The warnings, cautions, and instructions discussed in this instruction manual cannot cover all possible conditions and situations that may occur. It must be understood by the operator that common sense and caution are factors which cannot be built into this product, but must be supplied by the operator.

## Unpacking

When unpacking, check to make sure the following parts are included.

Assembled Compound Slide Miter Saw, dust collection bag, material Clamp (123), and single slide bar extension Bracket (121). If any parts are missing or broken, please call Harbor Freight Tools at the number on the cover of this manual as soon as possible.



## Installation

1. Place the Saw on the solid workbench capable of supporting the weight of the Miter Saw and all work pieces. (Do not carry the unit by the Handle or misalignment of the components may occur.)
2. Using a pencil, mark through the saw Base (118) holes onto the workbench.
3. Drill four 3/8 inch holes into the workbench for the mounting hardware.
4. Secure the unit to the workbench using bolts, nuts, lock washers (not supplied).
5. Insert the Bracket (121) into the holes on either side of the Saw.
6. Insert the material Clamp (123) into either side of the Base.
7. Check and tighten all bolts and adjustment screws.
8. Insert the Dust Collection Bag.

## Operation

**WARNING: Some dust created by power sanding, sawing, grinding, drilling, and other construction activities, contain chemicals known [to the State of California] to cause cancer, birth defects or other reproductive harm. Some examples of these chemicals are:**

- **Lead from lead-based paints**
- **Crystalline silica from bricks and cement or other masonry products**
- **Arsenic and chromium from chemically treated lumber**

Your risk from these exposures varies, depending on how often you do this type of work. To reduce your exposure to these chemicals: work in a well ventilated area, and work with approved safety equipment, such as those dust masks that are specially designed to filter out microscopic particles. (California Health & Safety Code 25249.5, et seq.)

### Caution:

The wood to be cut needs to be positioned under the center of the saw blade. If you are cutting a small workpiece, use a spacer block to move the wood to be cut so that you are cutting lined up with the center of the blade.





## Preparation to Cut Stock

1. Before cutting stock, verify that it fits the base and fence properly and secure in place.

The photos on the next page show the proper way to lay the stock on the base for cutting. These methods will keep the Saw Blade from binding with the stock, and keep it from rolling. Use the Clamp (123) to hold the stock in place for cutting.

2. Use the appropriate Saw Blade for the type of stock being cut. The Saw Blade provided is used for cutting wood.

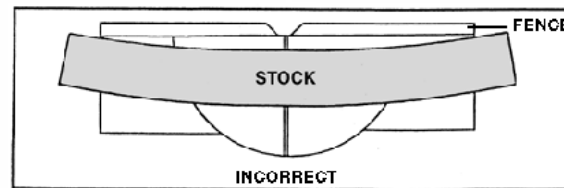
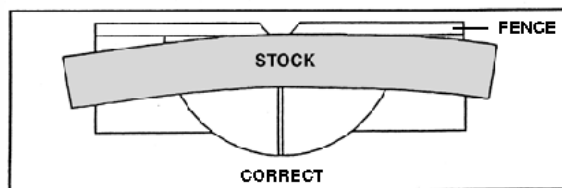
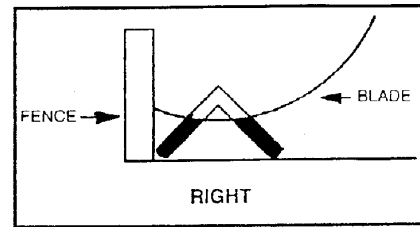
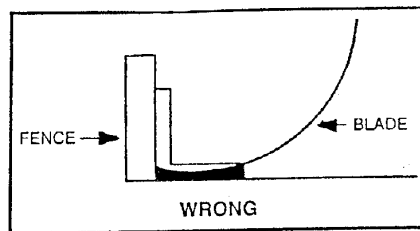

3. Raising the cutting arm: Push down slightly on the cutting arm while pulling out and turning (1/4 turn) the Arm Lock Button (see photo page 7). Once lock is released, lift the cutting arm.
4. If making a vertical cut, verify that the Saw Blade is 90 degrees to the Table (103). Use a tri-square (not included) against the Saw Blade and make adjustment using Adjusting Handle (73) (see photo page 7). Adjust the Saw Blade angle (see page 10).
5. If making bevel cuts, loosen the Adjusting Handle (73) and adjust the Saw Blade to the desired angle ranging from 0 to 45 degrees (positive stops at 0 and 45 degrees).  
**Note:** The 45 degree positive stop is adjustable. When adjusted, tighten Adjusting Handle again.
6. If making angle cuts, loosen the table Locking Pin (88), and push down on the Handle (107) lever to pass positive stops while moving the Handle to the desired angle (positive stops at 0, 15, 22.5, 30, and 45 degrees - left and right). Use the degrees Miter Scale (116) on the Base (118) as a guide. Tighten Locking Pin.
7. To slide the cutting arm backward, loosen the Bevel Knob (100), and slide the arm back. Tighten the Bevel Knob. See photo at the bottom of page 6.
8. Plug the Power Cord Plug (64) plug into the electrical outlet.



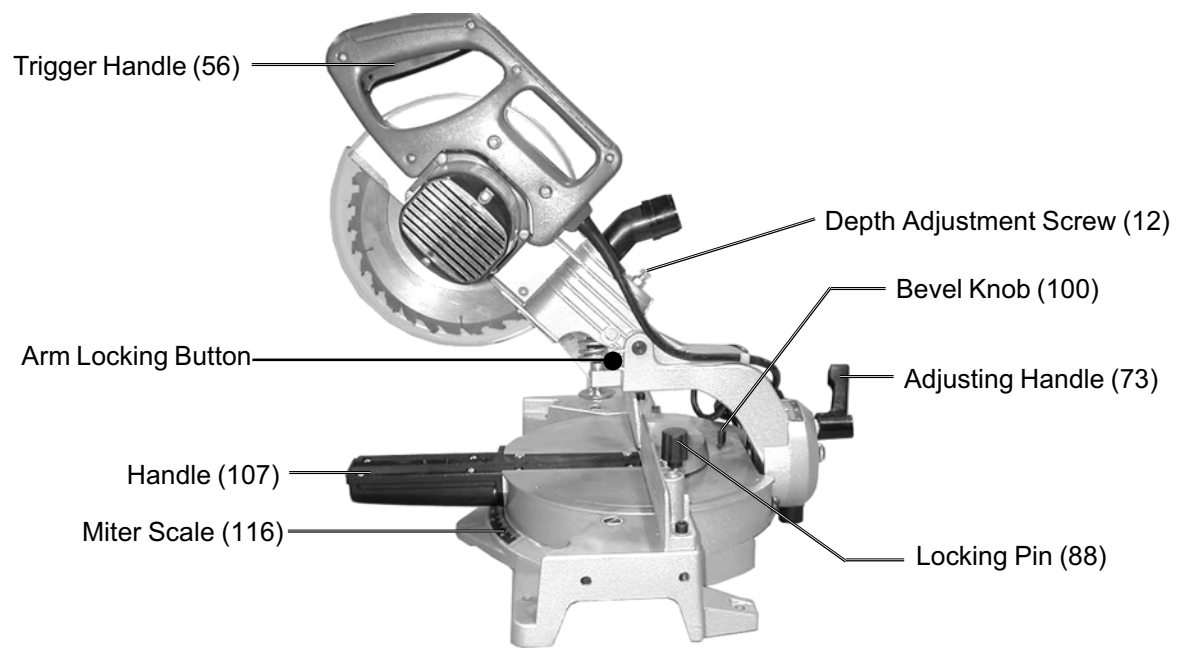

9. Turn on the saw by pressing in on the Trigger Handle (56).
10. When the Saw Blade comes to full speed, bring the Saw Blade down and begin cutting slowly through the stock.

**Warning: Avoid personal injury. Do not disable the Saw Blade safety Shield (67). Keep fingers and hands away from the moving blade.**

11. When the cut is finished, release the Trigger Handle.  
Wait for the Saw Blade to stop turning before reaching for the cut stock.
12. When you are finished using the saw, press the cutting head down until it locks into position.

### Replacing the Saw Blade

Refer to the photo at the top of the next page.

1. Unplug the Power Cord Plug from the electrical outlet.
2. Loosen Screw (71).
3. Push up on the right side of the safety Shield (67) releasing it from around the Screw.
4. Push the Shield assembly out of the way of the Fixed Shield (10).  
Optionally, you can remove the entire Shield assembly as shown on the next page.
5. Press in on the Spindle Lock (32) button.
6. Place a wrench on the Lock Bolt (19) and turn clockwise until the Bolt and Washer can be removed.



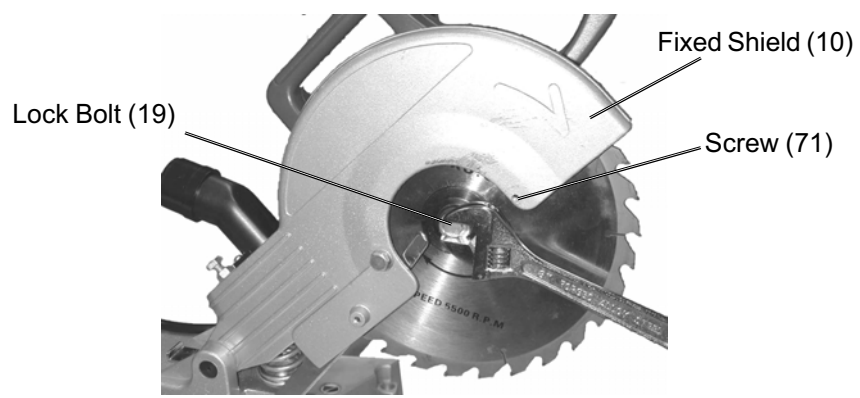
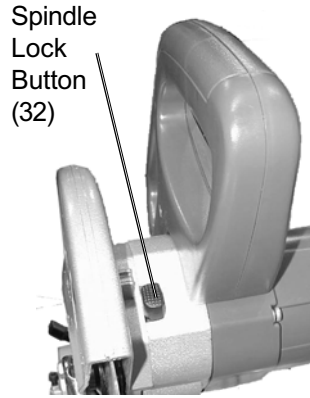

- Remove the existing Saw Blade and replace with another 10 inch blade.

The new Saw Blade has an arrow on it that must be pointing in the same direction as the large arrow on the outside of the Fixed Shield (10).

**Caution: Never use saw blades larger or smaller in diameter than 10 inches, and rated less than 5000 RPM operation.**

- Replace the Saw Blade Press Plates and Lock Bolt.
- Press in on the Spindle Lock button and retighten the Bolt in a counterclockwise direction.
- Replace the safety Shield to its original position and retighten the Screws.
- Press down on the saw Handle and verify that the safety Shield moves back properly, and that the blade does not touch the Fence or Table.

## Maintenance

### Replacing the Motor Brushes

It may become necessary at sometime to replace the motor brushes when the motor performance decreases, or stops working completely. The following steps describe their replacement. This procedure should be done by a qualified technician.

- Unplug the Power Cord Plug from the electrical outlet.
- Remove the Screws (51) and Cover (52) from the Field Case (43).

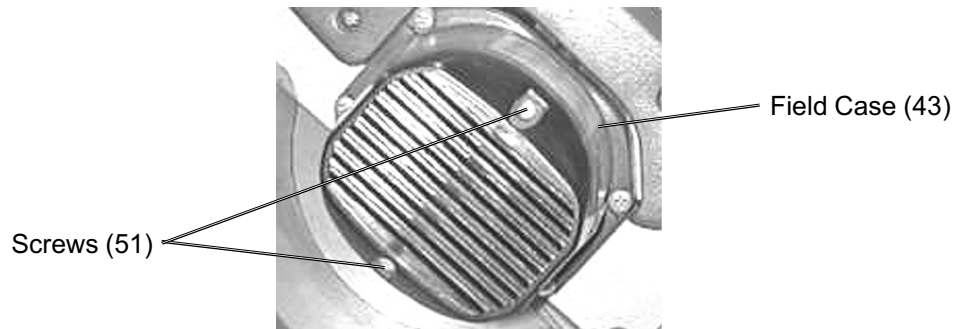





3. Remove the Brush Holders (48) and examine the old Brushes.

If the existing brushes are worn past 3/16 inch in length, or if the spring or shunt wires are burnt, they must be replaced. Never replace just one brush. If the brushes are only dirty, and not worn down, you can use a pencil eraser to clean the brush tips.

4. Replace the Field Case and Screws.
5. Connect the Power Cord Plug to an electrical outlet, then turn on the saw to test its operation.

### **General Maintenance**

1. After use, blow table and motor holes clean with an air hose.
2. Empty Dust Collector Bag after each use.

**Warning: Do not empty Dust Collection Bag around any sparks or flame. An explosion could occur.**

3. Periodically wipe down all metal parts with a clean cloth and a light oil.  
Never use solvents to clean plastic parts.
4. All motor bearings are factory lubricated and do not require maintenance.

### **Adjustments**

**Warning: Always disconnect power to the saw before making any adjustments. Adjustments should always be done by a qualified technician.**

#### **Fence 90 Degrees to Blade**

Follow these procedures if the Fence has been removed and replaced. The Blade must first be parallel to the Table Slot (above procedure).

1. Using a square, place one side against the Fence and the other on the left edge of the Saw Blade.
2. Loosen the two Hex Socket Head Screws on each side of the Fence.
3. Move the Fence 90 degrees to the left edge of the Table slot.
4. Retighten screws.



## Adjusting Depth of Cut

1. Loosen the Screw (71) and move Depth Stop to rear (away from blade) to make deeper cut. After making adjustment re-tighten Screw (71).

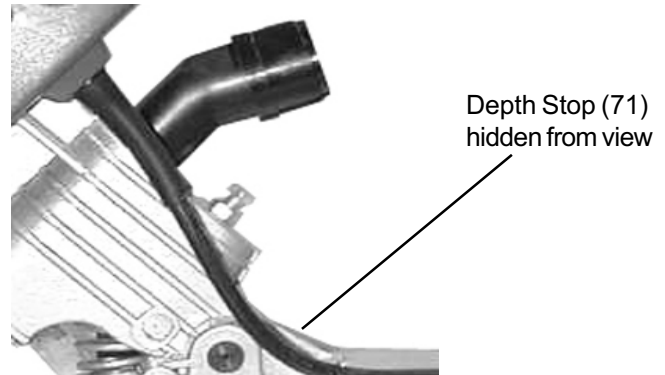

## Bevel Stop to 90 Degrees

1. Position saw bevel stop at 90 degrees and loosen bevel Adjusting Handle (73).
2. Tilt cutting arm all the way up to 90 degrees position on the Scale and retighten Adjusting Handle.
3. Lower the cutting head and place a Square on the surface of the Blade and the left side of the Table.
4. Loosen Lock Nut and turn Screw (A) until the Saw Blade touches the Left Kerf Plate and is at 90 degrees to Table. Retighten Lock Nut.

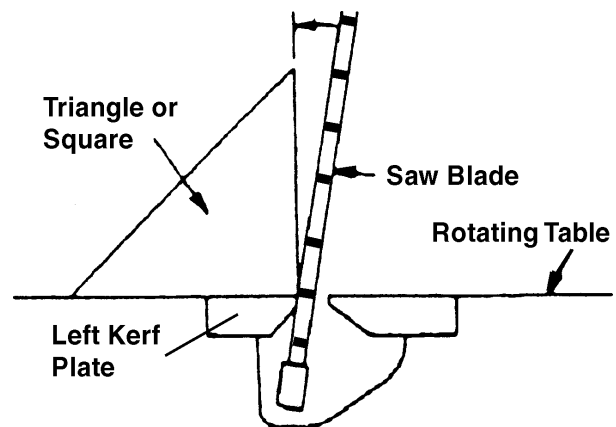
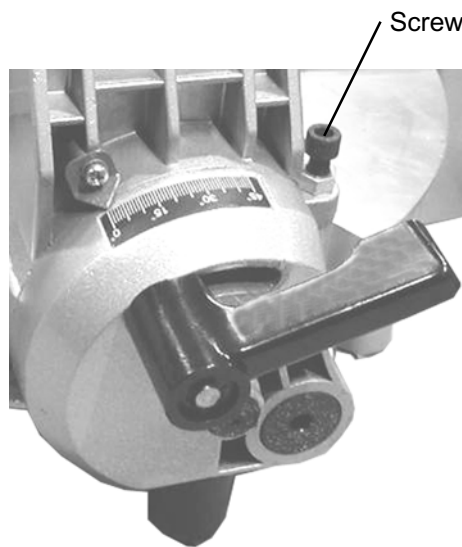

### PLEASE READ THE FOLLOWING CAREFULLY

THE MANUFACTURER AND/OR DISTRIBUTOR HAS PROVIDED THE PARTS DIAGRAM IN THIS MANUAL AS A REFERENCE TOOL ONLY. NEITHER THE MANUFACTURER NOR DISTRIBUTOR MAKES ANY REPRESENTATION OR WARRANTY OF ANY KIND TO THE BUYER THAT HE OR SHE IS QUALIFIED TO MAKE ANY REPAIRS TO THE PRODUCT OR THAT HE OR SHE IS QUALIFIED TO REPLACE ANY PARTS OF THE PRODUCT. IN FACT, THE MANUFACTURER AND/OR DISTRIBUTOR EXPRESSLY STATES THAT ALL REPAIRS AND PARTS REPLACEMENTS SHOULD BE UNDERTAKEN BY CERTIFIED AND LICENSED TECHNICIANS AND NOT BY THE BUYER. THE BUYER ASSUMES ALL RISK AND LIABILITY ARISING OUT OF HIS OR HER REPAIRS TO THE ORIGINAL PRODUCT OR REPLACEMENT PARTS THERETO, OR ARISING OUT OF HIS OR HER INSTALLATION OF REPLACEMENT PARTS THERETO.





Item #	Description
7	Shield Open Shaft
8	Screw
9	Ring
10	Fixed Shield
11	Dust Duct
12	Screw
13	Spring
14	Compression Spring
15	Baffle
16	Spring Stand
17	Spring Post
18	Screw
19	Lock Bolt
20	Saw Blade Press Plate
21	Front Cover
22	Spindle
23	Gear
24	Gear Washer
25	Screw
26	Check Ring
27	Wood Ruff Key
28	Bearing
29	Bearing
30	Axle Bearing
31	Button
32	Spindle Lock
33	Spring
34	Gear Case
35	Rubber Washer
36	Bearing
37	Armature
38	Bearing
39	Rubber Sleeve
40	Fan Baffle
41	Screw
42	Field

Item #	Description
43	Field Case
44	Name Plate
45	Washer
46	Screw
47	Brush
48	Brush Holder
49	Spring
50	Screw
51	Screw
52	Cover
53	Screw
54	Screw
55	Damshell Set (A)
56	Trigger Handle
57	Switch
58	Capacitor
59	Small Protector
60	Damshell Set (B)
61	Nut
62	Cord Clamp
63	Cord Protector
64	Power Cord Plug
65	Screw
66	Shield Press Board
67	Shield
68	Rorsion Spring
69	Rivel
70	Pivot Plate
71	Screw
72	Shield Retainer
73	Adjusting Handle
74	Washer
75	Stud
76	Nut
77	Guide-stem Stopper
78	Bevel Scale
79	Trunnion
80	Split Pin
81	Rubber Sleeve
82	Screw
83	Screw
84	Bevel Pointer

Item #	Description
85	Depth Stop
86	Screw
87	Pivot Shaft
88	Locking Pin
89	Rubber Sleeve
90	Arm
91	Screw
92	Nut
93	Screw
94	Gland
95	Felt Wiper
96	Bearing
97	Guide Stem
98	Screw
99	Clamp Knob
100	Bevel Knob
101	Baffle
102	Pin
103	Table
104	Left Kerf Plate
105	Flanged Sleeve
106	Right Kerf Plate
107	Handle
108	Slideway
109	Slideway Cap
110	Screw
111	Bearing
112	Small Guide Stem
113	Steering Ring
114	Screw
115	Change Direction Board
116	Miter Scale
117	Cap
118	Base
119	Rubber Base
120	Base Sell
121	Bracket
122	Saw Blade Spanner
123	Clamp
124	Dust Collector Cloth Bag
125	Saw Blade

**NOTE:** Some parts are listed and shown for illustration purposes only and are not available individually as replacement parts.



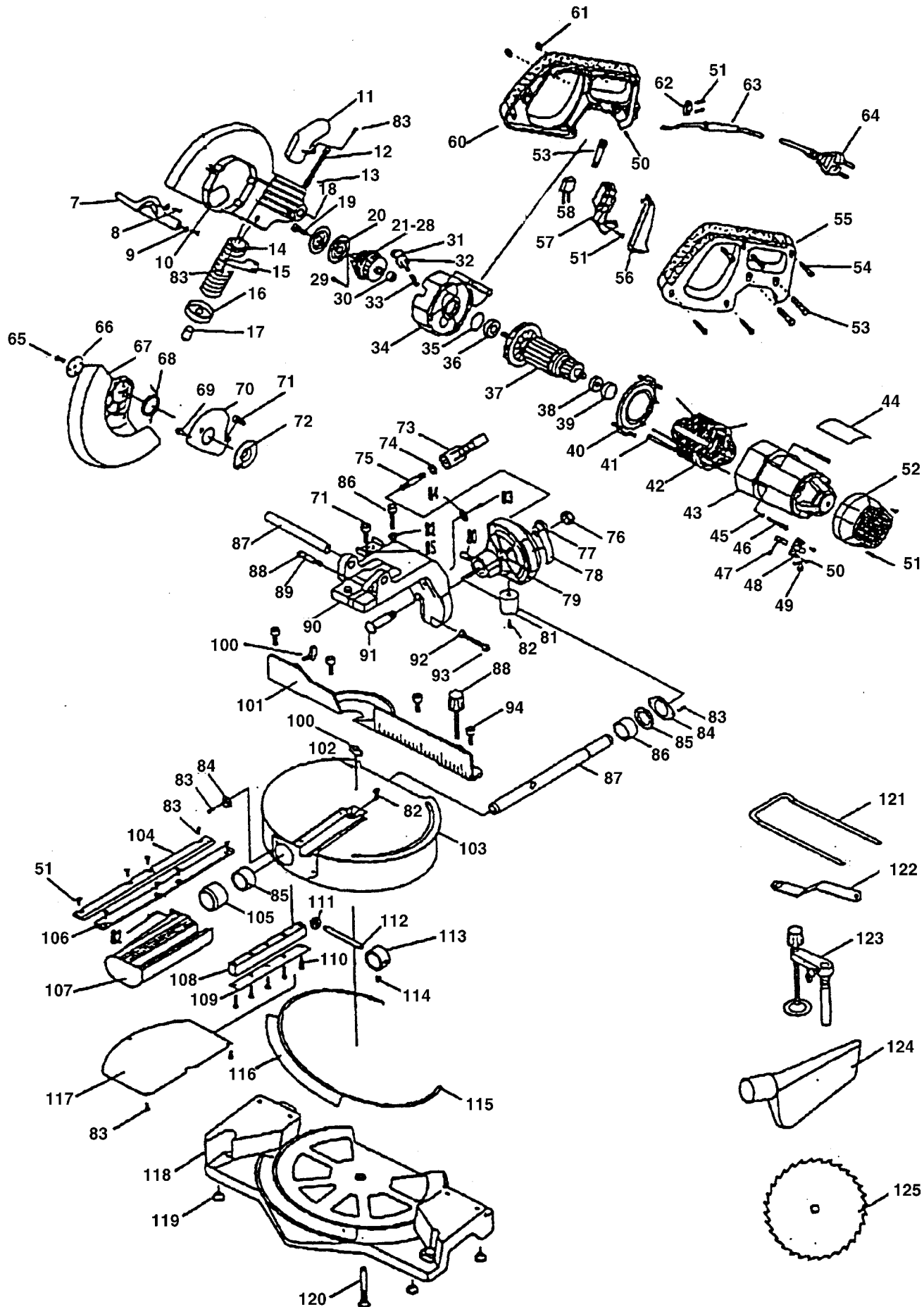

SKU 45885

Page 12

REV 04/03